



PINNACLE

## PINNACLE Wilo A Rated Pump + Blending Valves



Designed to work with manifolds of all types, on 210mm centres. The thermostatic blending valve is a bolt on unit providing a quick and simple system to install.

The thermostatic blending valve is the core of the control system. It is used with flow and return manifolds to control the flow temperature of water to the underfloor heating pipework. It mixes the hot water from the boiler and supplies the water back to the UFH pipe at the correct temperature. The mixing valve operates at a lower temperature than the radiator system, between 35°C and 60°C depending on the floor construction. The water supply temperature can be adjusted according to the structure of the floor.

### BENEFITS

- Self-controlled pump (Green Button technology)
- Unique LED user interface
- Self-protecting modes
- 130mm
- 1.5" Thread

### TECHNICAL DATA

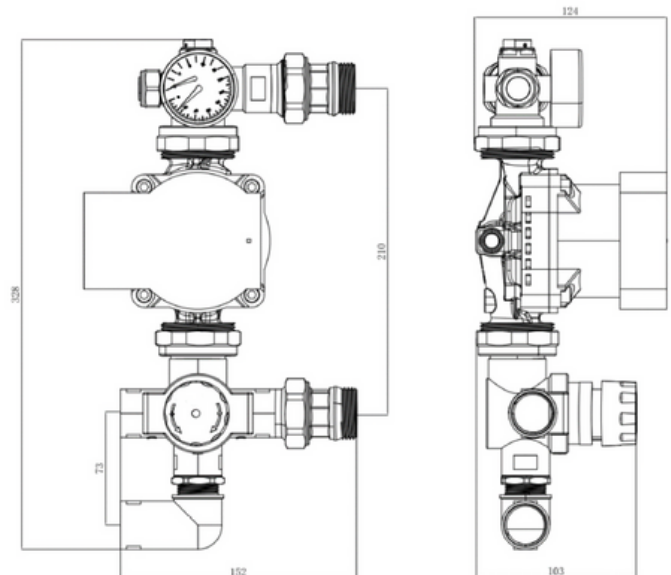

Technical Data	
Maximum Static Pressure	10 bar
Maximum Temperature	85°C
Adjustable Control Range	35°C to 60°C
Factory Pre-Set	45°C (Control knob is in the adjustable position)